

Stop valve in straightway form

DN 300 - 500

**ARI-STEVI® 405 / 460**

**Electric actuator AUMA SA with LE**

- Electric multiturn actuator capable of high closing pressures
- Enclosure IP 67
- 2 torque switches
- 2 travel switches
- Handwheel
- Overheating protection for motor as standard
- Additional devices available, e.g. potentiometer
- Explosion proof version available
- Encased linear thrust unit

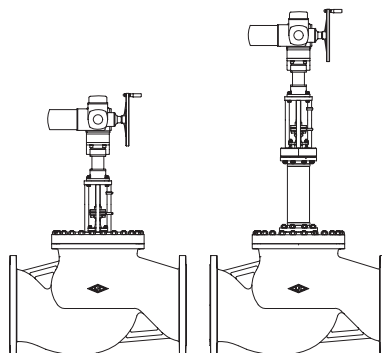

Page 2

**ARI-STEVI® 405 / 460**

**Pneumatic actuator ARI-DP**

- Reversible pneumatic actuator
- Actuator with rolling diaphragm
- Air supply pressure max. 6 bar
- Stem protection by bellow
- Maintenance-free O-ring sealing
- Assembly of additional devices acc. to DIN IEC 60534-6

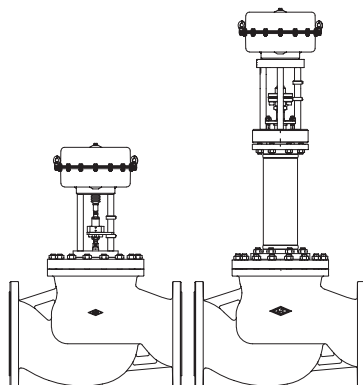

Page 8

**Features:**

- Maintenance-free EPDM- and bellows seal
- Burnished stem
- Three-ply bellows seal
- Travel indicator
- Reducible kvs-values

Stop valve in straightway form with electric actuator AUMA SA (DN300-500)

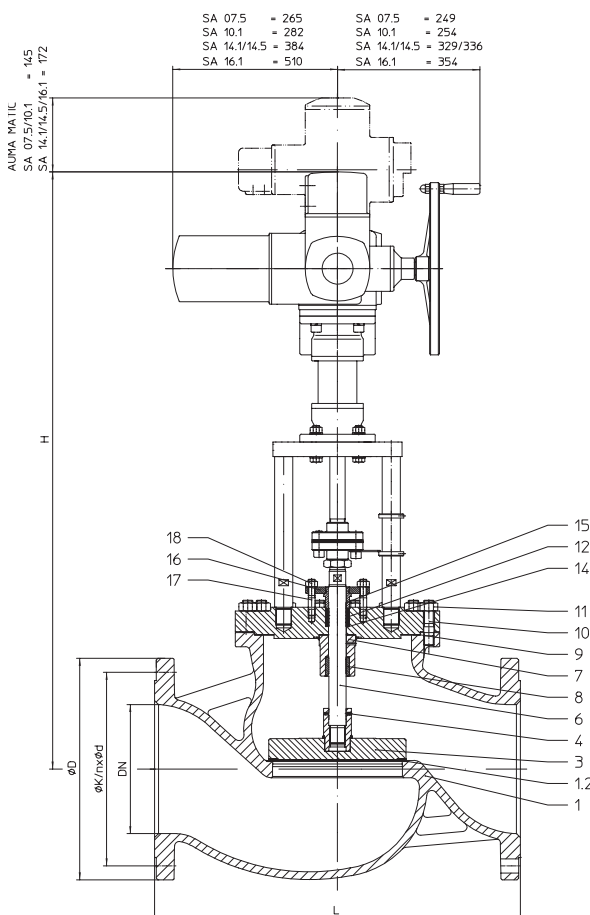

Figure	Nominal pressure	Material	Nominal diameter
12.405	PN16	EN-JL1040	DN300
22.405	PN16	EN-JS1049	DN300-350
34.405	PN25	1.0619+N	DN300-500
35.405	PN40	1.0619+N	DN300-500

Other materials and versions on request.

**Stem sealing**

- Fig. 405:
- PTFE-packing -10°C to 250°C
  - Pure graphite-packing -10°C to 450°C
  - EPDM-stem sealing 0°C to 130°C

**Plug design**

- standard:
- Isolation plug
- optional:
- Isolation plug with PTFE soft seat (max. 200°C)

**Shut off class (seat / plug leakage classes)**

- Metal seat - Leakage class 1 acc. to DIN 3230 T3 / B0
- Metal seat / PTFE - Leakage class 1 acc. to DIN 3230 T3 / B0

Closing pressures refer to page 6.

Technical data for actuator refer to data sheet.

**Selection of possible applications**

Industrial installations, processing technology, plant manufacturing, etc.  
(other applications on request)

**Selection of possible flow media**

Fig. 405: Cooling water, cooling brine, warm water, hot water, steam, gas, etc.  
(other flow media on request)

Fig. 405

**Dimensions and weights**

DN			300	350	400	500	
L		(mm)	850	980	1100	1350 (acc. to manufacturers standard)	
Fig. 405	H	(mm)	1189	--	--	--	
	SA 07.5 with LE 25.1	PN16	(kg)	498	--	--	--
		PN25-40	(kg)	518	--	--	--
	H	(mm)	1261	1318	1355	1462	
	SA 10.1 with LE 50.1	PN16	(kg)	506	680	--	--
		PN25-40	(kg)	526	760	1062	1564
	H	(mm)	1424	1481	1553	1640	
	SA 14.1 with LE 70.1	PN16	(kg)	563	736	--	--
		PN25-40	(kg)	583	816	1119	1621
	H	(mm)	1424	1481	1553	1640	
	SA 14.5 with LE 100.1	PN16	(kg)	565	738	--	--
		PN25-40	(kg)	585	818	1121	1623
	H	(mm)	1433	1490	1662	1749	
	SA 16.1 with LE 200.1	PN16	(kg)	617	790	--	--
PN25-40		(kg)	637	870	1173	1675	

Standard-flange dimensions refer to page 11. (For version with AUMA SA Ex other heights.)

Face-to-face dimension FTF series 1 according to DIN EN 558-1

**Parts**

Pos.	Description	Fig. 12.405	Fig. 22.405	Fig. 34.405 / Fig. 35.405
1	Body	EN-GJL-250 , EN-JL1040	EN-GJS-400-18U-LT, EN-JS1049	GP240GH+N, 1.0619+N
1.2	Seat	X20Cr13+QT, 1.4021+QT		G19 9 Nb Si, 1.4551
3	Plug *	P265GH, 1.0425 + S235JR, 1.0037 / G19 9 Nb Si, 1.4551		
4	Straight spin *	X10CrNi18-8, 1.4310		
6	Stem *	X20Cr13+QT, 1.4021+QT		
7	Stuffing box housing	P265GH, 1.0425 + S235JR, 1.0037		
8	Guide bushing	X20Cr13+QT, 1.4021+QT		
9	Gasket *	Pure graphite (CrNi laminated with graphite)		
10	Studs	25CrMo4, 1.7218		
11	Hexagon nuts	C35E, 1.1181		
12	Packing ring *	PTFE or Pure graphite		
14	Washer *	X5CrNi18-10, 1.4301		
15	Packing follower *	X20Cr13+QT, 1.4021+QT		
16	Packing box flange	X20Cr13+QT, 1.4021+QT		
17	Studs	25CrMo4, 1.7218		
18	Hexagon nuts	C35E, 1.1181		

\* Spare parts

Information / restriction of technical rules need to be observed!

ARI-Valves of EN-JL1040 are not allowed to be operated in systems acc. to TRD 110.

A production allowance acc. to TRB 801 No. 45 exists (acc. to TRB 801 No. 45 EN-JL1040 is not allowed.)

The engineer, designing a system or a plant, is responsible for the selection of the correct valve.

Stop valve in straightway form with electric actuator AUMA SA (DN300-500)

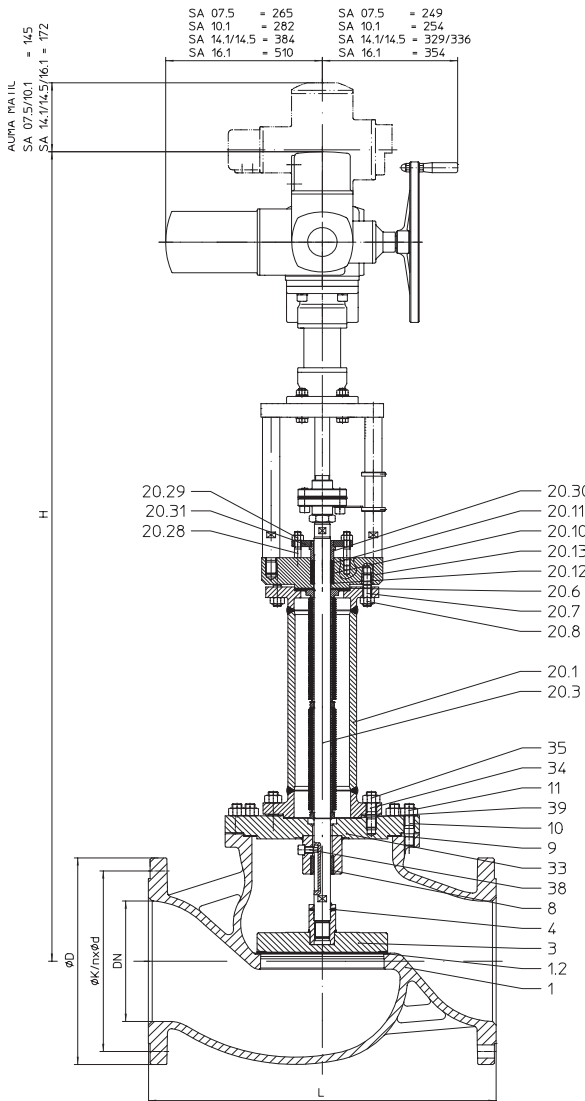

Figure	Nominal pressure	Material	Nominal diameter
12.460	PN16	EN-JL1040	DN300
22.460	PN16	EN-JS1049	DN300-350
34.460	PN25	1.0619+N	DN300-500
35.460	PN40	1.0619+N	DN300-500

Other materials and versions on request.

**Stem sealing**

Fig. 460: • Stainless steel bellows seal with safety stuffing box -60°C up to +450°C

**Plug design**

standard: • Isolation plug

optional:

- Isolation plug with PTFE soft seat (max. 200°C)

**Shut off class (seat / plug leakage classes)**

- Metal seat - Leakage class 1 acc. to DIN 3230 T3 / B0

- Metal seat / PTFE - Leakage class 1 acc. to DIN 3230 T3 / B0

Closing pressures refer to page 6.

Technical data for actuator refer to data sheet..

**Selection of possible applications**

Industrial installations, processing technology, plant manufacturing, etc.  
(other applications on request)

**Selection of possible flow media**

Fig. 460: Refrigerant, Cooling water, warm water, hot water, thermal oil, steam, gas, etc.  
(other flow media on request)

Fig. 460

**Dimensions and weights**

DN			300	350	400	500	
L		(mm)	850	980	1100	1350 (acc. to manufacturers standard)	
Fig. 460	H	(mm)	1817	--	--	--	
	SA 07.5 with LE 25.1	PN16	(kg)	575	--	--	--
		PN25-40	(kg)	595	--	--	--
	H	(mm)	1889	1947	1966	2084	
	SA 10.1 with LE 50.1	PN16	(kg)	583	759	--	--
		PN25-40	(kg)	603	839	1077	1584
	H	(mm)	2052	2110	2164	2262	
	SA 14.1 with LE 70.1	PN16	(kg)	640	816	--	--
		PN25-40	(kg)	660	896	1134	1641
	H	(mm)	2052	2110	2164	2262	
	SA 14.5 with LE 100.1	PN16	(kg)	642	818	--	--
		PN25-40	(kg)	662	898	1136	1643
	H	(mm)	2106	2164	2183	2381	
	SA 16.1 with LE 200.1	PN16	(kg)	694	870	--	--
PN25-40		(kg)	714	950	1188	1695	

Standard-flange dimensions refer to page 11. (For version with AUMA SA Ex other heights.)

Face-to-face dimension FTF series 1 according to DIN EN 558-1

**Parts**

Pos.	Description	Fig. 12.460	Fig. 22.460	Fig. 34.460 / Fig. 35.460
1	Body	EN-GJL-250 , EN-JL1040	EN-GJS-400-18U-LT, EN-JS1049	GP240GH+N, 1.0619+N
1.2	Seat	X20Cr13+QT, 1.4021+QT		G19 9 Nb Si, 1.4551
3	Plug *	P265GH, 1.0425 + S235JR, 1.0037 / G19 9 Nb Si, 1.4551		
4	Straight spin *	X10CrNi18-8, 1.4310		
8	Guide bushing	X20Cr13+QT, 1.4021+QT		
9	Gasket *	Pure graphite (CrNi laminated with graphite)		
10	Studs	25CrMo4, 1.7218		
11	Hexagon nuts	C35E, 1.1181		
20.1	Bellows housing	P265GH, 1.0425 / P235GH-TC1, 1.0345		
20.3	Stem- / Bellows unit *	X20Cr13+QT, 1.4021+QT / X6CrNiTi18-10, 1.4541		
20.6	Gasket *	Pure graphite (CrNi laminated with graphite)		
20.7	Studs	25CrMo4, 1.7218		
20.8	Hexagon nuts	C35E, 1.1181		
20.10	Packing ring *	PTFE or Pure graphite		
20.11	Packing ring *	PTFE or Pure graphite		
20.12	Washer *	X5CrNi18-10, 1.4301		
20.13	Stuffing box housing	P250 GH, 1.0460		
20.28	Studs	A4-70		
20.29	Hexagon nuts	A4		
20.30	Packing follower *	X20Cr13+QT, 1.4021+QT		
20.31	Packing box flange	X20Cr13+QT, 1.4021+QT		
33	Flange	P265GH, 1.0425		
34	Studs	25CrMo4, 1.7218		
35	Hexagon nuts	C35E, 1.1181		
38	Hexagon socket head screw	A2-70		
39	Gasket *	Pure graphite (CrNi laminated with graphite)		

\* Spare parts

Information / restriction of technical rules need to be observed!

ARI-Valves of EN-JL1040 are not allowed to be operated in systems acc. to TRD 110.

A production allowance acc. to TRB 801 No. 45 exists (acc. to TRB 801 No. 45 EN-JL1040 is not allowed.)

The engineer, designing a system or a plant, is responsible for the selection of the correct valve.

max. permissible closing pressures on flow-to-open P2 = 0 (Observe regulations, refer to page 11.)

DN		300	350	400	500
Standard Kvs-values	Seat-Ø (mm)	301	351	401	501
	Kvs-value	1635	2220	3180	4530
	Travel (mm)	75	90	100	115
Actuator <sup>1)</sup> <b>AUMA SA 07.5 with LE 25.1</b>	Closing pressure (bar)	I./II./III. 1,4			
	Torque (Nm)	60			
	Operating time <sup>2)</sup> (s)	41			
	Output drive (rpm)	22			
Actuator <sup>1)</sup> <b>AUMA SA 10.1 with LE 50.1</b>	Closing pressure (bar)	I./II./III. 3,3	2,3	2	1,2
	Torque (Nm)	120	120	120	120
	Operating time <sup>2)</sup> (s)	47	41	45	36
	Output drive (rpm)	16	22	22	32
Actuator <sup>1)</sup> <b>AUMA SA 14.1 with LE 70.1</b>	Closing pressure (bar)	I./II./III. 6,8	4,9	4	2,5
	Torque (Nm)	250	250	250	250
	Operating time <sup>2)</sup> (s)	40	48	39	45
	Output drive (rpm)	16	16	22	22
Actuator <sup>1)</sup> <b>AUMA SA 14.5 with LE 100.1</b>	Closing pressure (bar)	I./II./III. 15,4	11,2	8,9	5,6
	Torque (Nm)	500	500	500	500
	Operating time <sup>2)</sup> (s)	40	48	39	45
	Output drive (rpm)	16	16	22	22
Actuator <sup>1)</sup> <b>AUMA SA 16.1 with LE 200.1</b>	Closing pressure (bar)	I./II./III. 27,3	20	15,7	10
	Torque (Nm)	1000	1000	1000	1000
	Operating time <sup>2)</sup> (s)	51	42	47	39
	Output drive (rpm)	11	16	16	22
<b>I. Fig. 405: EPDM-stem sealing;</b>		<b>II. Fig. 405: PTFE-/ Pure graphite-packing;</b>		<b>III. Fig. 460: Bellows seal</b>	

<sup>1)</sup> Motor voltage: 400V 50Hz 3~  
 (Other voltages on request)  
 Technical data for actuator refer to price list.

<sup>2)</sup> Indicated operating times with 50Hz.



Stop valve in straightway form with pneumatic actuator DP (DN300)

Figure	Nominal pressure	Material	Nominal diameter
12.405 / 12.460	PN16	EN-JL1040	DN300
22.405 / 22.460	PN16	EN-JS1049	DN300
34.405 / 34.460	PN25	1.0619+N	DN300
35.405 / 35.460	PN40	1.0619+N	DN300

Other materials and versions on request.

**Stem sealing**

- Fig. 405:
- PTFE-packing -10°C to 250°C
  - Pure graphite-packing -10°C to 450°C
  - EPDM-stem sealing 0°C to 130°C

Fig. 460: • Stainless steel bellows seal with safety stuffing box -60°C up to +450°C

**Plug design**

- standard:
- Isolation plug
- optional:
- Isolation plug with PTFE soft seat (max. 200°C)

**Shut off class (seat / plug leakage classes)**

- Metal seat - Leakage class 1 acc. to DIN 3230 T3 / B0
- Metal seat / PTFE - Leakage class 1 acc. to DIN 3230 T3 / B0

Closing pressures refer to page 10.

Technical data for actuator refer to data sheet..

**Selection of possible applications**

Industrial installations, processing technology, plant manufacturing, etc.  
(other applications on request)

**Selection of possible flow media**

Fig. 405: Cooling water, cooling brine, warm water, hot water, steam, gas, etc.

Fig. 460: Refrigerant, Cooling water, warm water, hot water, thermal oil, steam, gas, etc.  
(other flow media on request)

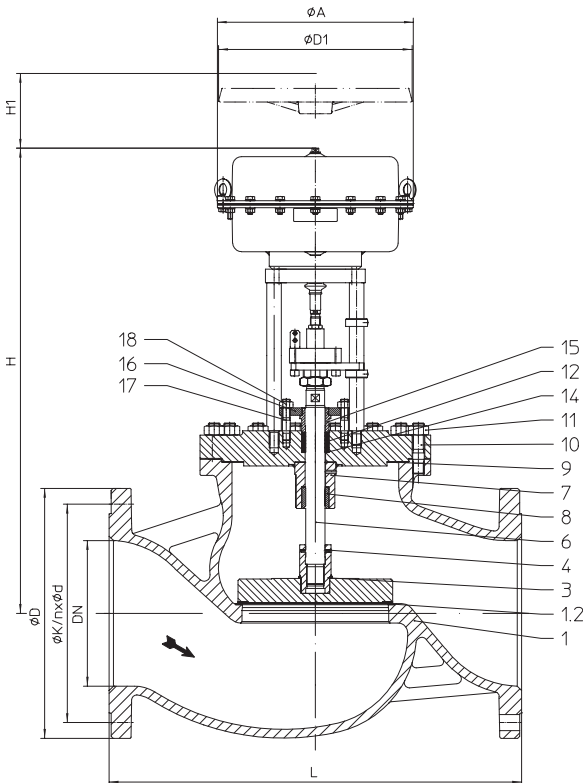

Fig. 405

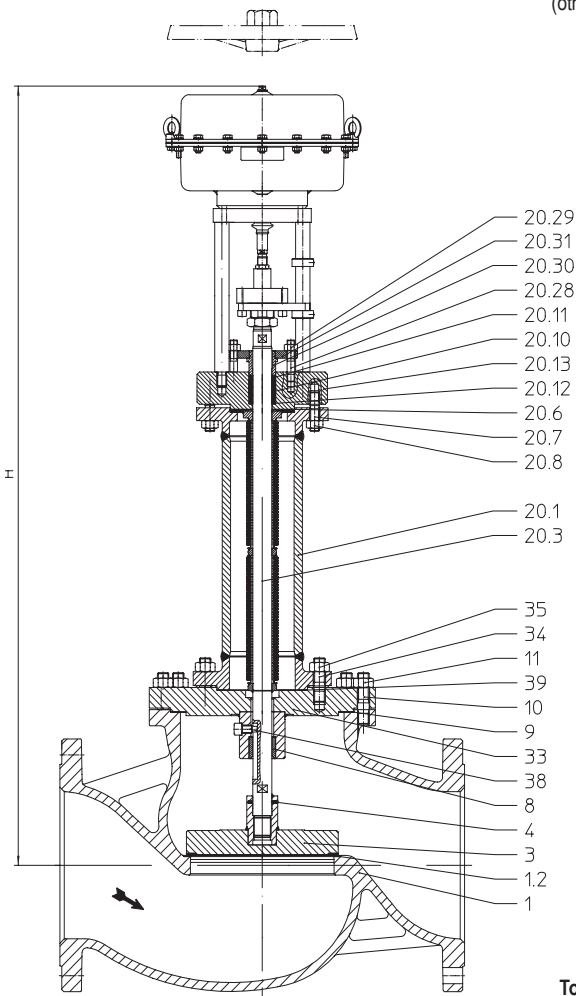
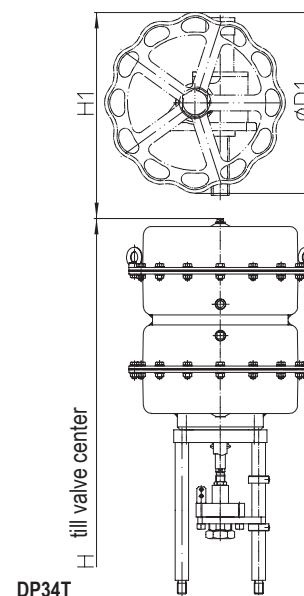

Fig. 460



**Top mounted handwheel**

Actuator		DP34	DP34T
Ø D1	(mm)	400	
H1	(mm)	470	630
Weight	(kg)	17	41

Technical data for actuator refer to data sheet DP32-34Tri.



**Dimensions and weights**

DN			300	
Actuator			DP 34	DP 34 T
L	(mm)		850	
Ø A	(mm)		405	
Fig. 405	H	(mm)	961	1179
	PN16	(kg)	507	578
	PN25-40	(kg)	527	598
Fig. 460	H	(mm)	1589	1807
	PN16	(kg)	585	656
	PN25-40	(kg)	605	676

Standard-flange dimensions refer to page 11.

Face-to-face dimension FTF series 1 according to DIN EN 558-1

**Parts**

Pos.	Description	Fig. 12.405 Fig. 12.460	Fig. 22.405 Fig. 22.460	Fig. 34.405 / Fig. 35.405 Fig. 34.460 / Fig. 35.460
1	Body	EN-GJL-250 , EN-JL1040	EN-GJS-400-18U-LT, EN-JS1049	GP240GH+N, 1.0619+N
1.2	Seat	X20Cr13+QT, 1.4021+QT		G19 9 Nb Si, 1.4551
3	Plug *	P265GH, 1.0425 + S235JR, 1.0037 / G19 9 Nb Si, 1.4551		
4	Straight spin *	X10CrNi18-8, 1.4310		
6	Stem *	X20Cr13+QT, 1.4021+QT		
7	Stuffing box housing	P265GH, 1.0425 + S235JR, 1.0037		
8	Guide bushing	X20Cr13+QT, 1.4021+QT		
9	Gasket *	Pure graphite (CrNi laminated with graphite)		
10	Studs	25CrMo4, 1.7218		
11	Hexagon nuts	C35E, 1.1181		
12	Packing ring *	PTFE or Pure graphite		
14	Washer *	X5CrNi18-10, 1.4301		
15	Packing follower *	X20Cr13+QT, 1.4021+QT		
16	Packing box flange	X20Cr13+QT, 1.4021+QT		
17	Studs	25CrMo4, 1.7218		
18	Hexagon nuts	C35E, 1.1181		
20.1	Bellows housing	P265GH, 1.0425 / P235GH-TC1, 1.0345		
20.3	Stem- / Bellows unit *	X20Cr13+QT, 1.4021+QT / X6CrNiTi18-10, 1.4541		
20.6	Gasket *	Pure graphite (CrNi laminated with graphite)		
20.7	Studs	25CrMo4, 1.7218		
20.8	Hexagon nuts	C35E, 1.1181		
20.10	Packing ring *	PTFE or Pure graphite		
20.11	Packing ring *	PTFE or Pure graphite		
20.12	Washer *	X5CrNi18-10, 1.4301		
20.13	Stuffing box housing	P250 GH, 1.0460		
20.28	Studs	A4-70		
20.29	Hexagon nuts	A4		
20.30	Packing follower *	X20Cr13+QT, 1.4021+QT		
20.31	Packing box flange	X20Cr13+QT, 1.4021+QT		
33	Flange	P265GH, 1.0425		
34	Studs	25CrMo4, 1.7218		
35	Hexagon nuts	C35E, 1.1181		
38	Hexagon socket head screw	A2-70		
39	Gasket *	Pure graphite (CrNi laminated with graphite)		

\* Spare parts

Information / restriction of technical rules need to be observed!

ARI-Valves of EN-JL1040 are not allowed to be operated in systems acc. to TRD 110.

A production allowance acc. to TRB 801 No. 45 exists (acc. to TRB 801 No. 45 EN-JL1040 is not allowed.)

The engineer, designing a system or a plant, is responsible for the selection of the correct valve.

max. permissible closing pressures on flow-to-open P2 = 0 (Observe regulations, refer to page 11.)

Spring opens on air failure				
DN		300		
Standard Kvs-values	Seat-Ø (mm)	301		
	Kvs-value	1635		
	Travel (mm)	75		
Actuator DP 34	Air supply pressure min. (bar)	4	I./II./III.	1,3
		5	I./II./III.	2,4
		6	I./II./III.	3,4
Actuator DP 34 T	Air supply pressure min. (bar)	3	I./II./III.	2,2
		4	I./II./III.	4,3
		5	I./II./III.	6,4
		6	I./II./III.	8,5
I. Fig. 405: EPDM-stem sealing;		II. Fig. 460: PTFE-/ Pure graphite-packing;		III. Fig. 460: Bellows seal
Air supply pressure max. of pneumatic actuators DP:      max. permissible      6 bar				

**Standard-flange dimensions**

Flanges acc. to DIN EN 1092-1/-2 (Flangeholes / -thickness tol. acc. To DIN 2533/2544/2545)

DN			300	350	400	500
PN16	ØD	(mm)	460	520	--	--
PN16	ØK	(mm)	410	470	--	--
PN16	n x Ød	(mm)	12 x 26	16 x 26	--	--
PN25	ØD	(mm)	485	555	620	730
PN25	ØK	(mm)	430	490	550	660
PN25	n x Ød	(mm)	16 x 30	16 x 33	16 x 36	20 x 36
PN40	ØD	(mm)	515	580	660	755
PN40	ØK	(mm)	450	510	585	670
PN40	n x Ød	(mm)	16 x 33	16 x 36	16 x 39	20 x 42

**Pressure-temperature-ratings acc. to DIN EN 1092-2**

Material			-60°C to <-10°C *	-10°C to 120°C	150°C	200°C	250°C	300°C	350°C	400°C	450°C
EN-JL1040	PN16	(bar)	--	16	14,4	12,8	11,2	9,6	--	--	--
EN-JS1049	PN16	(bar)	on request	16	15,5	14,7	13,9	12,8	11,2	--	--

**Pressure-temperature-ratings acc. to DIN EN 1092-1**

Material			-60°C to <-10°C *	-10°C to 50°C	100°C	150°C	200°C	250°C	300°C	350°C	400°C	450°C
1.0619+N	PN25	(bar)	18,7	25	23,3	21,7	19,4	17,8	16,1	15	14,4	13,9
1.0619+N	PN40	(bar)	30	40	37,3	34,7	30,2	28,4	25,8	24	23,1	22,2

Intermediate values for max. permissible operational pressures can be determined by linear interpolation of the given temperature / pressure chart.

\* Valve with extended bonnet, studs and nuts made of A4-70 (at temperatures below -10°C)

**Please indicate when ordering**

- Figure-No.
- Nominal diameter
- Nominal pressure
- Body material
- Plug design
- Kvs-value
- Stem sealing
- Actuator
- Special design / accessories

**Example:**

Figure 35.405; nominal diameter DN 300; nominal pressure PN 40; body material 1.0619+N; isolation plug; Kvs 301, Open/Close, EPDM stem sealing; AUMA SA 10.1

Dimensions in mm  
 Weights in kg  
 Pressures in barg (gauge)  
 1 bar  $\hat{=}$  10<sup>5</sup> Pa  $\hat{=}$  0,1 MPa  
 Kvs in m<sup>3</sup>/h

**Stem sealing**

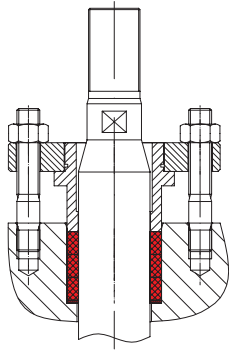

PTFE-/ Pure graphite-packing

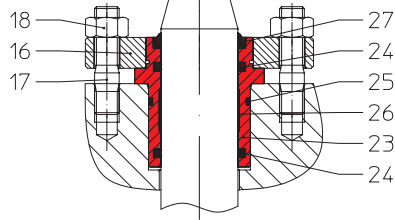

Pos.	Description	
16	Packing box flange	X20Cr13+QT, 1.4021+QT
17	Studs	25CrMo4, 1.7218
18	Hexagon nuts	C35E, 1.1181
23	Stem guiding *	X20Cr13+QT, 1.4021+QT
24	Sealing ring *	EPDM 70
25	O-ring	EPDM 70
26	Strip *	PTFE
27	Scraper *	NBR

EPDM-stem sealing

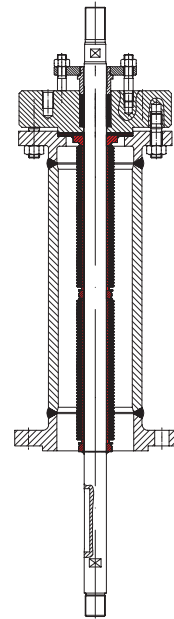

Bellows seal with safety stuffing box

**Plug designs**

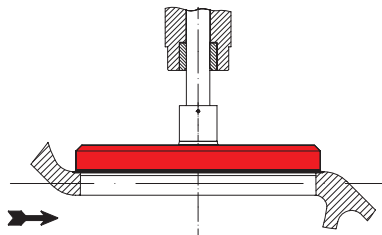

Isolation plug

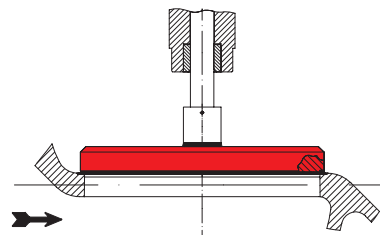

Isolation plug with PTFE soft seat

... also with other actuators: (on request)

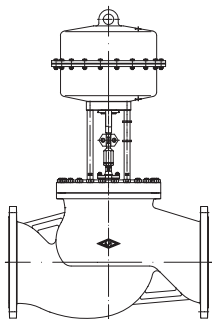

with pneumatic actuators

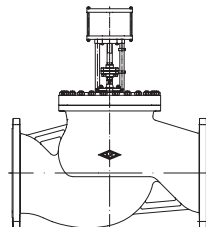

with hydraulic actuators

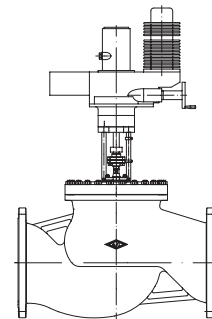

with other electric actuators



**Technology for the Future.**  
GERMAN QUALITY VALVES

ARI-Armaturen Albert Richter GmbH & Co. KG, D-33756 Schloß Holte-Stukenbrock,  
Tel. +49 52 07 / 994-0, Telefax +49 52 07 / 994-158 or 159 Internet: <http://www.ari-armaturen.com> E-mail: [info.vertrieb@ari-armaturen.com](mailto:info.vertrieb@ari-armaturen.com)