

## 3-way control valve in mixing and diverting design

1/2" - 6"

### STEVI® 450 / 451 Electric actuator ARI-PREMIO

- Enclosure IP 65
- 2 torque switches
- 1 travel switch
- Handwheel
- Additional devices available, e.g. potentiometer

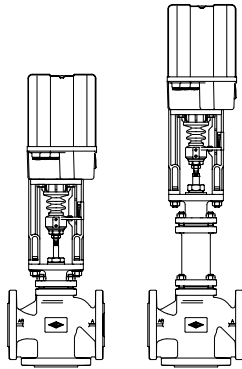

Page 2

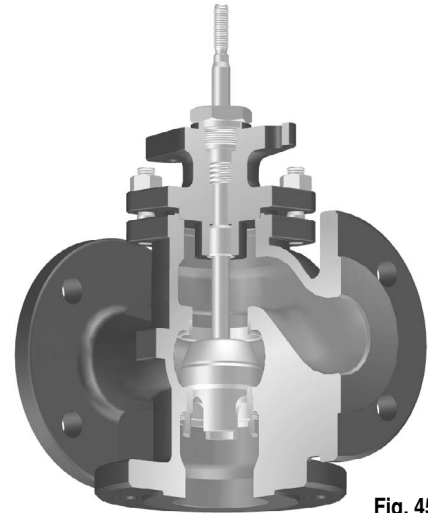
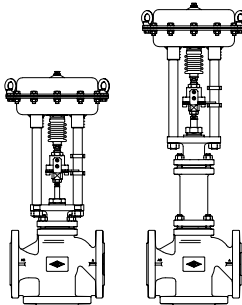

Fig. 450

### STEVI® 450 / 451 Pneumatic actuator DP32 - DP34

- Reversible pneumatic actuator
- Actuator with rolling diaphragm
- Air supply pressure max. 87 psi
- Stem protection by bellow
- Maintenance-free O-ring sealing
- Assembly of additional devices acc. to DIN IEC 60534-6



Page 4

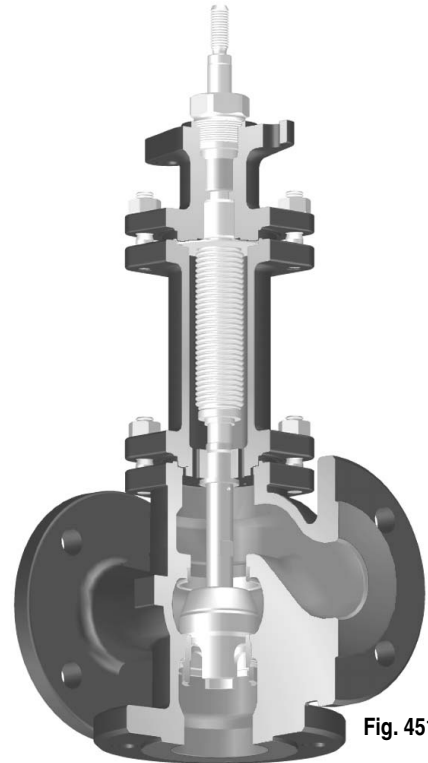
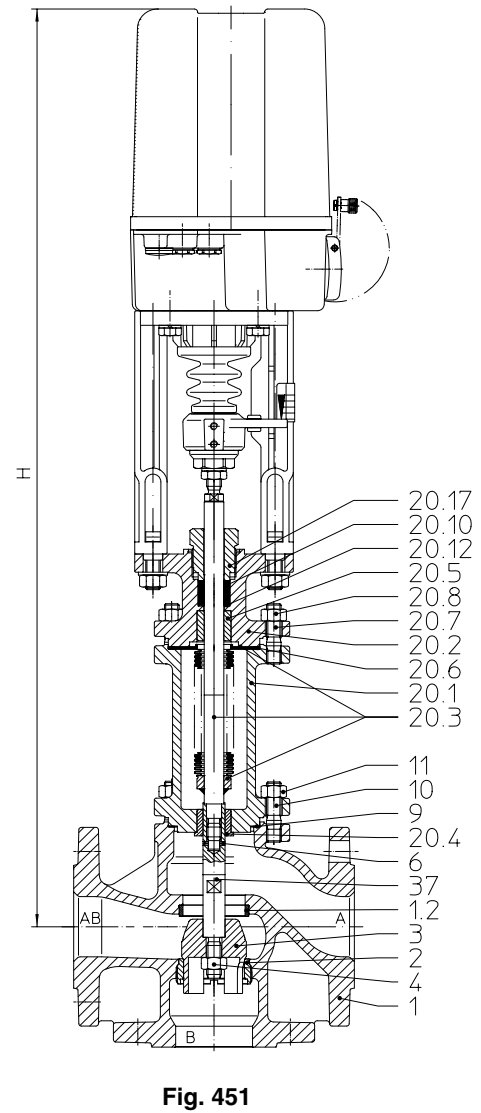
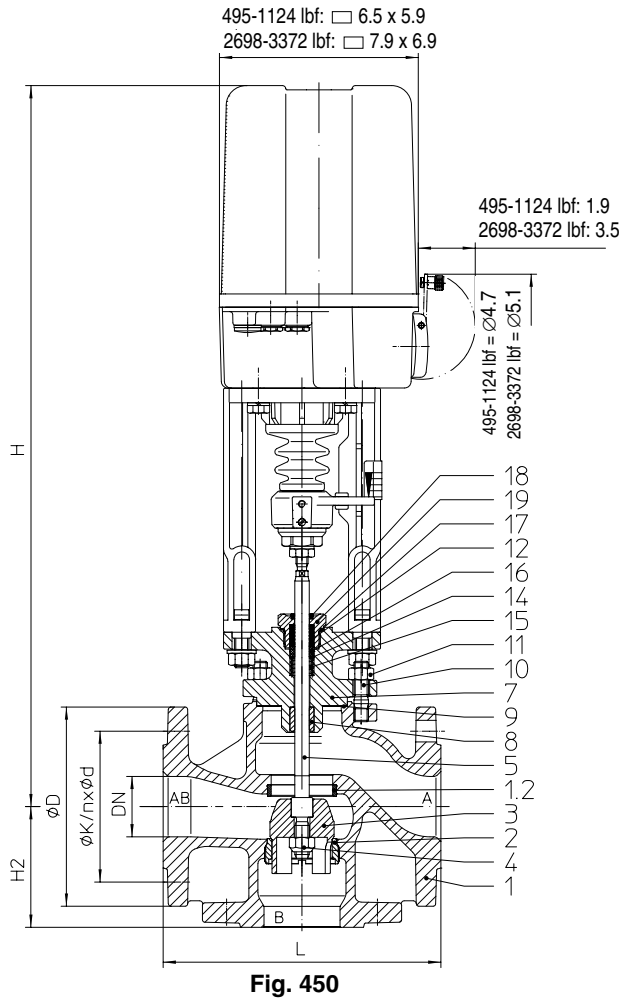

Fig. 451

### Features:

- Compact design
- Precision guided stem
- Burnished stem
- Tapered seat ring
- Seat options available
- Reducible kvs-values
- Rangeability 30 : 1
- Guided plug
- Spring loaded PTFE-V ring packing unit
- Two-ply bellows seal
- Travel indicator

(Material and Figure-No. refer to technical data or part list.)



**Diverting construction** from 1 1/2" upwards  
(further information refer to page 10)

**Heights and weights**

Size				1/2"	3/4"	1"	1 1/4"	1 1/2"	2"	2 1/2"	3"	4"	5"	6"	
...450	H	(in)		22.2	22.2	22.4	23.4	23.6	23.5	25	25.6	26.3	29.1	31.5	
	495 lbf	(2,2 kN)	PN16/	23.1/24.3	25.4/26.7	27.6/28.8	33.3/35.3	40.6/43.2	48.9/52.2	63.7/68.3	78/83.7	115/124/	161/221	--	
	1124 lbf	(5 kN)	PN25-40 (lb)	25.6/26.7	27.8/29.1	30/31.3	35.7/37.7	43/45.6	51.4/54.7	66.1/70.8	80.5/86.2	117/126	163/223	223/318	
	H	(in)				28.3	29.3	29.5	29.4	30.9	31.5	32.2	34.9	37.3	
	2698 lbf	(12 kN)	PN16/				38.8/40.1	44.5/46.5	51.8/54.5	60.2/63.5	75/79.6	89.3/95	126/135	172/232	232/326
	3372 lbf	(15 kN)	PN25-40 (lb)												
...451	H	(in)		29.5	29.5	29.6	30.7	30.3	30	34.2	34.7	35.4	43	44.3	
	495 lbf	(2,2 kN)	PN16/	29.8/31.3	32/33.7	34.6/36.6	39.9/42.3	50.5/54	57.5/61.7	77.6/83.5	99.4/107	139/150	--	--	
	1124 lbf	(5 kN)	PN25-40 (lb)	32.2/33.7	34.4/36.2	37/39	42.3/44.8	52.9/56.4	60/64.2	80/86	102/110	141/152	185/247	245/342	
	H	(in)				35.6	36.6	36.2	35.9	40.1	40.6	41.3	48.9	50.2	
	2698 lbf	(12 kN)	PN16/				45.9/47.8	51.1/53.6	61.7/62.3	68.8/73	88.8/94.8	111/119	150/161	194/256	254/351
	3372 lbf	(15 kN)	PN25-40 (lb)												

Other dimensions refer to page 9.

**max. permissible closing pressures for both seat positions** on flow-to-open  $P_2 = 0$  (Observe pressure-temperature-limits on page 9)

Mixing function		Size	1/2"	3/4"	1"	1 1/4"	1 1/2"	2"	2 1/2"	3"	4"	5"	6"
		Seat-Ø A / B (in)	0.83/0.79	0.83/0.98	1.06/1.06	1.22/1.26	1.61/1.58	2.01/1.97	2.60/2.36	3.19/2.95	3.98/3.74	4.72/4.72	5.51/5.51
AB	Standard Cv-values	4.6	7.3	12	18	29	46	73	116	185	289	370	
	Reduced Cv-values <sup>3)</sup>	2.9	4.6	7.3	12	18	29	46	73	116	185	289	
	Travel (in)	0.79						1.18			1.97		
	Actuator <sup>1)</sup> ARI-PREMIO 495 lbf (2,2 kN)	Closing pressure (psi)	I.	580	521	446	314	186	116	63	38	22	
		II.	580	488	418	294	173	107	56	34	119		
		III.	445	436	394	276	154	95	52	31	17		
	Operating time <sup>2)</sup> (Operating speed 0.01 in/s)	(s)	53						79				
Actuator <sup>1)</sup> ARI-PREMIO 1124 lbf (5 kN)	Closing pressure (psi)	I.		580	580	580	482	308	179	115	72	49	35
		II.		580	580	580	469	300	172	111	69	47	33
		III.	580	580	580	580	450	288	168	108	67	44	31
	Operating time <sup>2)</sup> (Operating speed 0.01 in/s)	(s)	53						79			132	
Actuator <sup>1)</sup> ARI-PREMIO 2698 lbf (12 kN)	Closing pressure (psi)	I.					580	580	468	308	196	137	100
		II.					580	580	462	303	193	135	98
		III.					580	580	458	300	191	132	96
	Operating time <sup>2)</sup> (Operating speed 0.03 in/s)	(s)					25		38			63	
Actuator <sup>1)</sup> ARI-PREMIO 3372 lbf (15 kN)	Closing pressure (psi)	I.							580	390	249	175	127
		II.							580	386	246	173	126
		III.							580	383	245	170	124
	Operating time <sup>2)</sup> (Operating speed 0.01 in/s)	(s)							79			132	
Diverting function		Size	1/2"	3/4"	1"	1 1/4"	1 1/2"	2"	2 1/2"	3"	4"	5"	6"
		Seat-Ø A / B (in)	0.83/0.79	0.83/0.98	1.06/1.06	1.22/1.26	1.57/1.57	1.97/1.97	2.36/2.36	2.95/2.95	3.54/3.54	4.13/4.13	4.92/4.92
AB	Standard Cv-values	4.6	7.3	12	18	16	29	52	69	110	197	231	
	Reduced Cv-values <sup>3)</sup>	2.9	4.6	7.3	12	--	--	--	--	--	--	--	
	Travel (in)	0.79						1.18					
	Actuator <sup>1)</sup> ARI-PREMIO 495 lbf (2,2 kN)	Closing pressure (psi)	I.	372	261	223	157	194	119	78	46	30	19
		II.	349	244	209	147	181	111	70	41	26	17	
		III.	223	218	197	138	161	98	65	38	24		
Operating time <sup>2)</sup> (Operating speed 0.01 in/s)		(s)	53						79				
Actuator <sup>1)</sup> ARI-PREMIO 1124 lbf (5 kN)	Closing pressure (psi)	I.	580	580	558	397	502	318	217	136	92	65	44
		II.	580	580	543	387	488	309	209	131	89	62	42
		III.	580	580	531	378	469	296	204	128	86	59	40
	Operating time <sup>2)</sup> (Operating speed 0.01 in/s)	(s)	53						79				
Actuator <sup>1)</sup> ARI-PREMIO 2698 lbf (12 kN)	Closing pressure (psi)	I.			580	580	580	580	564	360	248	179	125
		II.			580	580	580	580	556	355	245	176	123
		III.			580	580	580	580	551	351	242	173	121
	Operating time <sup>2)</sup> (Operating speed 0.03 in/s)	(s)			25				38				
Actuator <sup>1)</sup> ARI-PREMIO 3372 lbf (15 kN)	Closing pressure (psi)	I.							580	456	315	228	160
		II.							580	451	312	225	158
		III.							580	447	309	222	155
	Operating time <sup>2)</sup> (Operating speed 0.01 in/s)	(s)							79				

I. Fig. 450: PTFE-V-ring unit;    II. Fig. 450: Pure graphite packing;    III. Fig. 451: Bellows seal

1) Motor voltage:    230V 50/60Hz    Special voltages: 24V 50/60Hz; 115V 50/60Hz  
 Technical data for actuator refer to data sheet ARI-PREMIO

2) Indicated operating times with 50 Hz.

3) Cv-value reducible on request (2 threaded seat rings required)

(Material and Figure-No. refer to technical data or part list.)

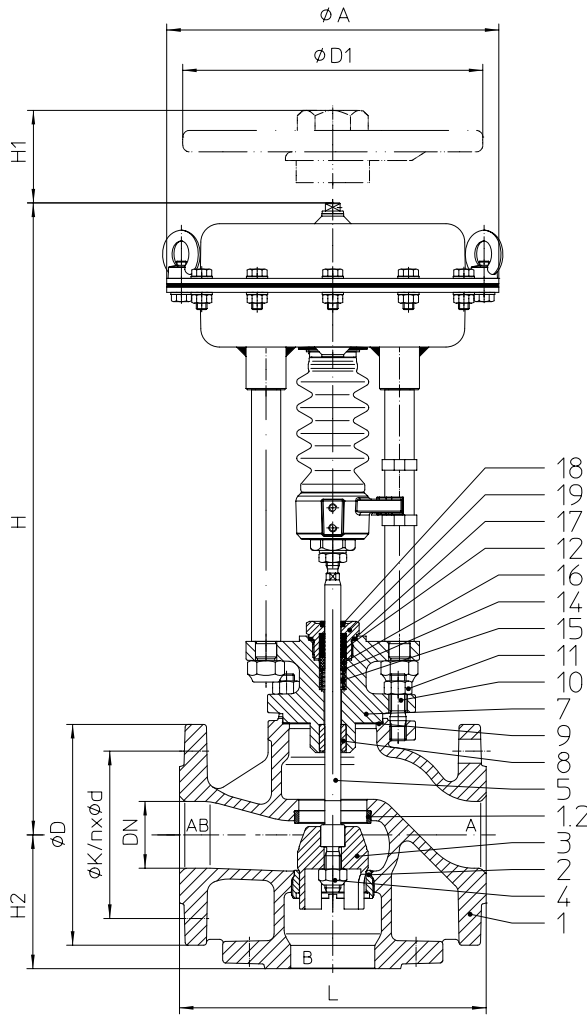

**Fig. 450**

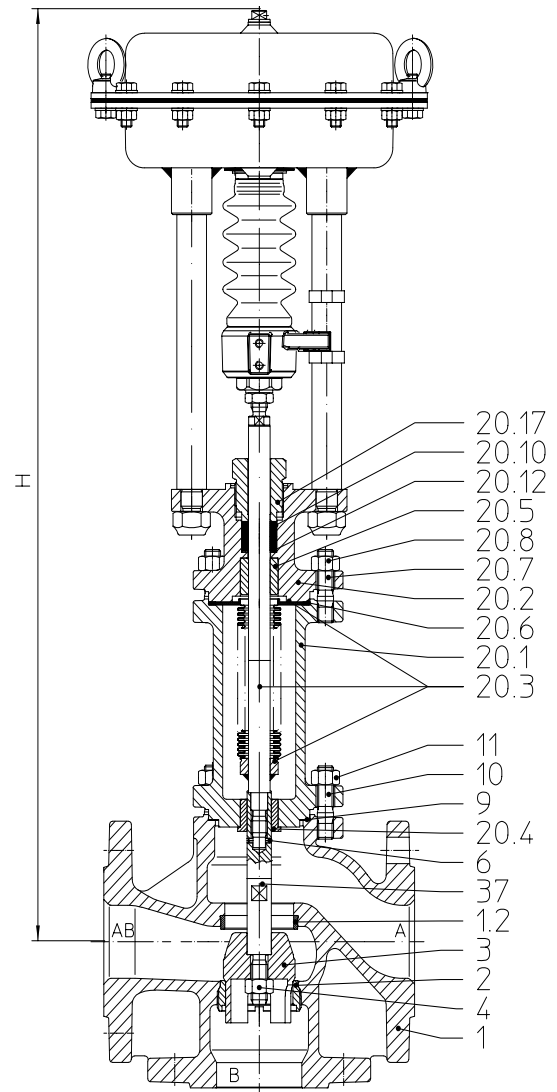

**Fig. 451**

**Diverting plug 1 1/2" upwards (further information refer to page 10)**

**Heights and weights**

Size		1/2"	3/4"	1"	1 1/4"	1 1/2"	2"	2 1/2"	3"	4"	5"	6"	
DP 32	ø A (in)	9.84											
	...450	H (in)	17.7	17.7	17.9	18.9	19.1	19.1	20.5	21.1	21.9		
		PN16/PN25-40 (lb)	31.1/32.2	33.3/34.6	35.5/36.6	41.2/43.2	48.5/51.2	56.9/60.2	71.6/76.3	86.0/91.7	124/132		
	...451	H (in)	25.0	25.0	25.2	26.2	25.8	25.6	29.7	30.2	30.9		
	PN16/PN25-40 (lb)	37.7/39.2	39.9/41.7	42.5/44.5	47.8/50.3	58.4/62.0	65.5/69.7	85.5/91.5	107/115	146/159			
DP 33	ø A (in)	11.81											
	...450	H (in)	19.9	19.9	20.0	21.1	21.3	21.2	22.6	23.3	24.0	25.9	28.3
		PN16/PN25-40 (lb)	44.3/45.4	46.5/47.8	48.7/50.0	54.5/56.4	61.7/64.4	70.1/73.4	84.9/89.5	99.2/105	137/146	181/243	243/337
	...451	H (in)	27.2	27.2	27.3	28.3	28.0	27.7	31.9	32.4	33.0	39.8	41.1
	PN16/PN25-40 (lb)	50.9/52.5	53.1/54.9	55.8/57.8	61.1/63.5	71.6/75.2	78.7/82.9	98.8/105	121/129	159/172	203/265	265/359	
DP 34	ø A (in)	15.94											
	...450	H (in)							28.0	28.6	29.3	30.4	32.8
		PN16/PN25-40 (lb)							151/156	165/171	203/212	247/309	309/403
	...451	H (in)							37.2	37.7	38.3	44.4	45.7
	PN16/PN25-40 (lb)							165/171	187/195	225/238	269/331	331/426	

Other dimensions refer to page 9.

max. permissible closing pressures for both seat positions on flow-to-open P2 = 0 (Observe pressure-temperature-limits on page 9)

**Spring closes port A -> AB or Spring closes port B -> AB**

Mixing function 		Size		1/2"	3/4"	1"	1 1/4"	1 1/2"	2"	2 1/2"	3"	4"	5"	6"			
		Standard Cv-values		4.6	7.3	12	18	29	46	73	116	185	289	370			
		Reduced Cv-values <sup>2)</sup>		2.9	4.6	7.3	12	18	29	46	73	116	185	289			
		Travel (in)		0.79						1.18			1.97				
Actuator DP 32	Spring range (psi)	Air supply pressure min. (psi)	3 - 15	17	I.	80	47	38	21								
					II.	33	14										
					III.												
				6 - 17	23	I.	270	183	155	105	57	32					
						II.	224	150	126	84	44	23					
						III.	125	116	102	67	25						
				12 - 35	46	I.	580	455	389	273	160	99	54	32	17		
						II.	580	422	360	252	147	91	46	28	15		
						III.	382	373	336	235	128	78	42	25			
				22 - 36	58	I.		580	580	567	341	217					
						II.		580	580	547	329	209					
						III.	580	580	580	530	310	197					
				29 - 48	77	I.				580	471	302					
						II.				580	458	293					
						III.				580	439	281					
Actuator DP 33	Spring range (psi)	Air supply pressure min. (psi)	3 - 15	17	I.	192 <sup>c)</sup>	128 <sup>c)</sup>	107 <sup>c)</sup>	70 <sup>c)</sup>	35 <sup>c)</sup>	18 <sup>c)</sup>						
					II.	146 <sup>c)</sup>	94 <sup>c)</sup>	78 <sup>c)</sup>	50 <sup>c)</sup>	23 <sup>c)</sup>							
					III.	72 <sup>a)</sup>	63 <sup>a)</sup>	54 <sup>a)</sup>	33 <sup>a)</sup>								
				6 - 17	23	I.	496 <sup>c)</sup>	344 <sup>c)</sup>	293 <sup>c)</sup>	204 <sup>c)</sup>	118 <sup>c)</sup>	72 <sup>c)</sup>	36	21			
						II.	449 <sup>c)</sup>	311 <sup>c)</sup>	265 <sup>c)</sup>	184 <sup>c)</sup>	105 <sup>c)</sup>	63 <sup>c)</sup>	30	16			
						III.	277 <sup>a)</sup>	268 <sup>a)</sup>	241 <sup>a)</sup>	166 <sup>a)</sup>	86 <sup>a)</sup>	51 <sup>a)</sup>	26 <sup>a)</sup>				
				12 - 35	46	I.	580 <sup>a)</sup>	580 <sup>a)</sup>	580 <sup>a)</sup>	472 <sup>a)</sup>	283 <sup>a)</sup>	179 <sup>a)</sup>	101	64	38		
						II.	580 <sup>a)</sup>	580 <sup>a)</sup>	580 <sup>a)</sup>	451 <sup>a)</sup>	270 <sup>a)</sup>	171 <sup>a)</sup>	94	59	36		
						III.	580	580	580	434	251	158	90	57	34		
				22 - 44	65	I.							214	139	87		
						II.							207	134	84		
						III.							203	132	82		
				25 - 39	64	I.				580 <sup>a)</sup>	580 <sup>a)</sup>	421 <sup>a)</sup>					
						II.				580 <sup>a)</sup>	580 <sup>a)</sup>	412 <sup>a)</sup>					
						III.				580	580	400					
				29 - 58 (3 - 54)	87 (87)	I.						(580)	295	192	121		
						II.						(573)	288	188	119		
						III.						(561)	284	185	117		
Actuator DP 34	Spring range (psi)	Air supply pressure min. (psi)	3 - 15	17	I.					367 <sup>b)</sup>	21 <sup>b)</sup>						
					II.					30 <sup>b)</sup>	17 <sup>b)</sup>						
					III.					26 <sup>e)</sup>	14 <sup>e)</sup>						
				6 - 17	23	I.						102 <sup>b)</sup>	64 <sup>b)</sup>	39 <sup>b)</sup>	25	17	
						II.							95 <sup>b)</sup>	60 <sup>b)</sup>	36 <sup>b)</sup>	23	16
						III.							91 <sup>d)</sup>	57 <sup>d)</sup>	34 <sup>d)</sup>	21 <sup>a)</sup>	
				12 - 35	46	I.							232	150	94	65	46
						II.							225	146	92	63	45
						III.							221 <sup>b)</sup>	143 <sup>b)</sup>	90 <sup>b)</sup>	60	43
				22 - 44 (31 - 44)	65 (74)	I.							(580)	(431)	(279)	134	98
						II.							(580)	(426)	(273)	132	96
						III.										129	94
				29 - 58 (35 - 52)	87 (87)	I.								(495)	(317)	184	134
						II.								(491)	(315)	182	132
						III.										179	130

**I. Fig. 450: PTFE-V-ring unit;      II. Fig. 450: Pure graphite-packing;      III. Fig. 451: Bellows seal**

Air supply pressure max. of pneumatic actuators DP: 87 psi

Air supply pressure max. limit of control valve: a) 73 psi      b) 65 psi      c) 58 psi      d) 51 psi      e) 44 psi

Higher closing pressures for Size 5"-6" in connection with DP34T on request!

<sup>2)</sup> Cv-value reducible on request (2 threaded seat rings required)

max. permissible closing pressures for both seat positions on flow-to-open P2 = 0 (Observe pressure-temperature-limits on page 9)

Spring closes port A -> AB or Spring closes port B -> AB

<div style="display: flex; align-items: center;"> <div style="text-align: center; margin-right: 10px;"> <b>Diverting function</b>  </div> <div> <b>Size</b>                      Standard Cv-values                      Reduced Cv-values <sup>2)</sup>                      Travel (in)                 </div> </div>		1/2"	3/4"	1"	1 1/4"	1 1/2"	2"	2 1/2"	3"	4"	5"	6"			
				4.6	7.3	12	18	16	29	52	69	110	197	231	
		2.9	4.6	7.3	12	--	--	--	--	--	--	--			
		0.79						1.18							
Actuator DP 32	Spring range (psi)	Air supply pressure min. (psi)	17	I.	40	24	19								
				II.	17										
				III.											
			23	I.	135	92	77	52	60	33	17.4				
				II.	112	72	63	42	47	25					
				III.	62	58	51	33	27						
			46	I.	326	227	195	136	168	102	66	39	24	16	
				II.	302	211	180	126	154	94	58	34	21		
				III.	191	187	168	118	135	81	53	30	19		
			58	I.	580	465	399	284	356	224					
				II.	580	449	385	273	343	215					
				III.	416	412	373	265	323	203					
			77	I.		580	546	389	491	310					
				II.		580	531	378	477	302					
				III.	577	573	519	370	458	289					
Actuator DP 33	Spring range (psi)	Air supply pressure min. (psi)	17	I.	96 <sup>c)</sup>	64 <sup>c)</sup>	54 <sup>c)</sup>	35 <sup>c)</sup>	38 <sup>c)</sup>	19 <sup>c)</sup>					
				II.	73 <sup>c)</sup>	47 <sup>c)</sup>	39 <sup>c)</sup>	25 <sup>c)</sup>	25 <sup>c)</sup>						
				III.	36 <sup>a)</sup>	32 <sup>a)</sup>	27 <sup>a)</sup>	16 <sup>a)</sup>							
			23	I.	248 <sup>c)</sup>	172 <sup>c)</sup>	147 <sup>c)</sup>	102 <sup>c)</sup>	124 <sup>c)</sup>	74 <sup>c)</sup>	46	26	15		
				II.	225 <sup>c)</sup>	155 <sup>c)</sup>	132 <sup>c)</sup>	92 <sup>c)</sup>	110 <sup>c)</sup>	66 <sup>c)</sup>	38	21			
				III.	139 <sup>a)</sup>	134 <sup>a)</sup>	120 <sup>a)</sup>	83 <sup>a)</sup>	91 <sup>a)</sup>	53 <sup>a)</sup>	33 <sup>a)</sup>	18 <sup>a)</sup>			
			46	I.	551 <sup>a)</sup>	388 <sup>a)</sup>	333 <sup>a)</sup>	236 <sup>a)</sup>	295 <sup>a)</sup>	185 <sup>a)</sup>	124	76	50	34	23
				II.	528 <sup>a)</sup>	372 <sup>a)</sup>	319 <sup>a)</sup>	226 <sup>a)</sup>	282 <sup>a)</sup>	176 <sup>a)</sup>	116	71	47	32	20
				III.	344	339	307	217	262	163	111	67	44	28	18
			65	I.							259	163	111	79	54
				II.							251	158	108	76	52
				III.							246	155	105	73	50
			64	I.	580 <sup>a)</sup>	580 <sup>a)</sup>	580 <sup>a)</sup>	537 <sup>a)</sup>	580 <sup>a)</sup>	433 <sup>a)</sup>					
				II.	580 <sup>a)</sup>	580 <sup>a)</sup>	580 <sup>a)</sup>	527 <sup>a)</sup>	580 <sup>a)</sup>	424 <sup>a)</sup>					
				III.	580	580	580	518	580	412					
87 (87)	I.				(580)		(580)	356	225	155	111	77			
	II.				(580)		(580)	348	220	151	108	74			
	III.				(580)		(577)	343	217	149	104	72			
Actuator DP 34	Spring range (psi)	Air supply pressure min. (psi)	17.4	I.					47 <sup>b)</sup>	26 <sup>b)</sup>	16 <sup>b)</sup>				
				II.					39 <sup>b)</sup>	21 <sup>b)</sup>					
				III.					34 <sup>e)</sup>	18 <sup>e)</sup>					
			23	I.							125 <sup>b)</sup>	76 <sup>b)</sup>	51 <sup>b)</sup>	35	23
				II.							117 <sup>b)</sup>	71 <sup>b)</sup>	47 <sup>b)</sup>	32	21
				III.							112 <sup>d)</sup>	68 <sup>d)</sup>	45 <sup>d)</sup>	28 <sup>a)</sup>	18 <sup>a)</sup>
			46	I.							280	177	121	86	59
				II.							272	172	117	83	57
				III.							267 <sup>b)</sup>	169 <sup>b)</sup>	115 <sup>b)</sup>	80	55
			5	I.							580	503	348	252	177
				II.							580	498	345	249	175
				III.										246	172
			6	I.								578	401	290	204
				II.								573	397	287	202
				III.										284	199

I. Fig. 450: PTFE-V-ring unit

II. Fig. 450: Pure graphite-packing

III. Fig. 451: Bellows seal

Air supply pressure max. of pneumatic actuators DP: 87 psi

Air supply pressure max. limit of control valve: a) 73 psi b) 65 psi c) 58 psi d) 51 psi e) 44 psi

Higher closing pressures for Size 5"-6" with DP34T on request!

<sup>2)</sup> Cv-value reducible on request (2 threaded seat rings required)

**Cv-value chart**

Size	1/2"	3/4"	1"	1 1/4"	1 1/2"	2"	2 1/2"	3"	4"	5"	6"	Travel (in)
Cv	Seat-∅ A / B (in)											
Mixing valve	2.9	0.83/0.79										0.79
	4.6	0.83/0.79	0.83/0.98									
	7.3		0.83/0.98	1.06/1.06								
	12			1.06/1.06	1.22/1.26							
	18				1.22/1.26	1.61/1.57						
	29					1.61/1.57	2.01/1.97					
	46						2.01/1.97					1.18
	46							2.60/2.36				
	73							2.60/2.36	3.19/2.95			
	116								3.19/2.95	3.98/3.74		
	185									3.98/3.74		
	185										4.72/4.72	
289										4.72/4.72	5.51/5.51	1.97
370											5.51/5.51	
Diverting valve	2.9	0.83/0.79										0.79
	4.6	0.83/0.79	0.83/0.98									
	7.3		0.83/0.98	1.06/1.06								
	12			1.06/1.06	1.22/1.26							
	16					1.57/1.57						
	18				1.22/1.26							
	29						1.97/1.97					1.18
	52							2.36/2.36				
	69								2.95/2.95			
	110									3.54/3.54		
197										4.13/4.13		
231											4.92/4.92	

Figure		PN16 - 12.450 <sup>4)</sup> / 12.451 <sup>4)</sup>	PN16 - 22.450 / 22.451 PN25 - 23.450 <sup>4)</sup> / 23.451 <sup>4)</sup>	PN25 - 34.450 / 34.451 PN40 - 35.450 / 35.451	PN40 - 55.450 <sup>4)</sup> / 55.451 <sup>4)</sup>
Pos.	Description	Material codes			
1	Body	SA 278 Class 40	SA 395	SA 216 WCB	SA 351 CF 8
1.2	Seat ring	AISI 420			--
2	Seat ring *	AISI 420			AISI 316 TI
3	Plug *	AISI 420			AISI 316 TI
4	Self-locking nut *	AISI 316 TI			
5	Stem *	AISI 420			AISI 316 TI
6	Straight pin *	AISI 302			AISI 321
7	Mounting bonnet	SA 395		SA 216 WCB	SA 351 CF 8
8	Guide bushing	AISI 420 (hardened)			AISI 316 TI
9	Gasket *	CrNi laminated both sides with pure graphite			
10	Studs	AISI 1035 / 1038			AISI 316
11	Hexagon nuts	AISI 1035			AISI 316
12	V-ring unit *	PTFE			
13	Packing ring *	PTFE or pure graphite			
14	Washer *	SA 240 Gr. 304			
15	Spring *	AISI 302			
16	Bushing *	Reinforced PTFE			
17	Sealing ring *	Soft iron / Copper			AISI 316 TI
18	Scraper *	Reinforced PTFE			
19	Screw joint*	AISI 303			
20.1	Bellows housing	SA 395		SA 216 WCB	SA 351 CF 8
20.2	Mounting bonnet	SA 395		SA 216 WCB	SA 351 CF 8
20.3	Stem- / Bellows unit *	AISI 420 / SA 182 F 321			AISI 316 TI
20.4	Guide bushing	AISI 420 (hardened)			AISI 316 TI
20.5	Guide bushing	AISI 420 (hardened)			AISI 316 TI
20.6	Gasket *	CrNi lam. both sides with pure graphite			
20.7	Studs	AISI 1035 / 1038			AISI 316
20.8	Hexagon nuts	AISI 1035			AISI 316
20.10	Packing ring *	Pure graphite			
20.12	Washer *	SA 240 Gr. 304			
20.17	Screw joint *	AISI 303			
31	Plug *	AISI 420			AISI 316 TI
32	Distance bushing *	SA 240 Gr. 304			
37	Stem adapter *	AISI 420			AISI 316 TI
38	Stem adapter *	AISI 420			AISI 316 TI
40	Plug *	AISI 420			AISI 316 TI
41	Stem adapter *	AISI 420			AISI 316 TI
42	Screw joint *	AISI 303			

\* Spare parts

<sup>4)</sup> up to Size 4"

**Please indicate when ordering:**

- |                          |                  |                                  |
|--------------------------|------------------|----------------------------------|
| 1. Figure-No.            | 4. Body material | 7. Stem sealing                  |
| 2. Nominal diameter (DN) | 5. Plug design   | 8. Actuator                      |
| 3. Nominal pressure (PN) | 6. Cv-value      | 9. Special version / accessories |

**Example:**

Figure 35.450; size 4"; nominal press. PN 40 bar; body material cast steel; mixing construction; Cv 185; stem sealing PTFE-V-ring unit; ARI-PREMIO 1124 lbf (5 kN).

Dimensions in inch (in)

1 in  $\hat{=}$  25.4 mm

Weights in pound (lb)

1 lb  $\hat{=}$  0.45 kg

Pressures in psig (gauge)

1 psi  $\hat{=}$  0.07 bar / 1 bar  $\hat{=}$  14.5 psi

Cv in US gal/min

Cv 1  $\hat{=}$  Kvs 0.86

1 lbf  $\hat{=}$  4.45 N

1 ft lbf  $\hat{=}$  1.36 Nm



### Technical data of the valve

<b>Type:</b>	Control valve Fig. 450-451	<b>Plug design:</b>	Parabolic plug / V-port plug																		
<b>Size:</b>	Size 1/2" - 6"	<b>Guiding:</b>	Stem and port guiding																		
<b>Nominal pressure:</b>	PN 16, PN 25, PN 40	<b>Flow characteristic:</b>	linear																		
<b>Stem sealing:</b>	Fig. 450 • PTFE-V-ring unit +14°F up to +428°F • PTFE-packing +14°F up to +482°F • Pure graphite-packing +14°F up to +842°F	<b>Rangeability:</b>	30 : 1																		
	Fig. 451 • Stainless steel bellows seal with safety stuffing box -76°F up to +842°F	<b>Shut off classes:</b>	Metal seat - Leakage class IV acc. to ANSI / FCI 70-2																		
<b>Body material:</b>	Cast iron (to 4") PN16 Fig. 12.450 / 12.451 Spheroidal graph. iron PN16 Fig. 22.450 / 22.451 Sph. graph. iron (to 4") PN25 Fig. 23.450 / 23.451 Cast steel PN25 Fig. 34.450 / 34.451 Cast steel PN40 Fig. 35.450 / 35.451 Stainless steel (to 4") PN40 Fig. 55.450 / 55.451 Other materials and executions on request	<b>Selection of possible applications:</b>	<table border="0"> <tr> <td><b>Fig. 450</b></td> <td><b>Fig. 451</b></td> </tr> <tr> <td>• Cooling water</td> <td>• Refrigerant</td> </tr> <tr> <td>• Cooling brine</td> <td>• Cooling water</td> </tr> <tr> <td>• Warm water</td> <td>• Warm water</td> </tr> <tr> <td>• Hot water</td> <td>• Hot water</td> </tr> <tr> <td>• Steam</td> <td>• Heat transfer oil</td> </tr> <tr> <td>• Gas</td> <td>• Steam</td> </tr> <tr> <td></td> <td>• Gas</td> </tr> <tr> <td colspan="2" style="text-align: center;">- other applications on request -</td> </tr> </table>	<b>Fig. 450</b>	<b>Fig. 451</b>	• Cooling water	• Refrigerant	• Cooling brine	• Cooling water	• Warm water	• Warm water	• Hot water	• Hot water	• Steam	• Heat transfer oil	• Gas	• Steam		• Gas	- other applications on request -	
<b>Fig. 450</b>	<b>Fig. 451</b>																				
• Cooling water	• Refrigerant																				
• Cooling brine	• Cooling water																				
• Warm water	• Warm water																				
• Hot water	• Hot water																				
• Steam	• Heat transfer oil																				
• Gas	• Steam																				
	• Gas																				
- other applications on request -																					

Technical data for actuator refer to corresponding actuator data sheets.

### Pressure-temperature-ratings acc. to DIN EN1092-1 / -2

Observe regulations

acc. to DIN EN 1092-2		Temperature									
Material	PN	-76°F up to <14°F*	14°F up to 248°F	302°F	392°F	482°F	572°F	662°F	752°F	842°F	
SA 278 Cl. 40	16 bar	---	232 psi	208 psi	185 psi	162 psi	139 psi	---	---	---	
	16 bar	on request	232 psi	225 psi	213 psi	201 psi	186 psi	162 psi	---	---	
SA 395	25 bar	on request	362 psi	352 psi	333 psi	316 psi	290 psi	254 psi	---	---	

acc. to DIN EN 1092-1		Temperature									
Material	PN	-76°F up to <14°F*	14°F up to 122°F	212°F	302°F	392°F	482°F	572°F	662°F	752°F	842°F
SA 216 WCB	25 bar	271 psi	362 psi	338 psi	314 psi	281 psi	258 psi	233 psi	217 psi	209 psi	201 psi
	40 bar	435 psi	580 psi	541 psi	503 psi	438 psi	412 psi	374 psi	348 psi	335 psi	322 psi
SA 351 CF 8 M	40 bar	580 psi	580 psi	540 psi	490 psi	451 psi	425 psi	400 psi	387 psi	371 psi	--

Intermediate values for max. permissible operational pressures can be determined by linear interpolation of the given temperature / pressure chart.

\* Valve with extended bonnet, studs and nuts made of AISI 316 required (at temperatures below -14°F)

### Valve dimensions

Face to face length FTF series 1 according to DIN EN 558-1 (DIN 3202-1 series F1)

Size		1/2"	3/4"	1"	1 1/4"	1 1/2"	2"	2 1/2"	3"	4"	5"	6"	8"	10"
L	(in)	5.12	5.91	6.30	7.09	7.87	9.06	11.42	12.20	13.78	15.75	18.90	23.62	28.74
H2	(in)	2.56	2.76	2.95	3.15	3.54	3.94	4.72	5.12	5.91	7.87	8.27	14.96	17.32

### Flange dimensions

Flanges acc. to DIN EN 1092-1 (Flangeholes/-thickness tolerances acc. to DIN 2533 / 2544 / 2545)

Size		1/2"	3/4"	1"	1 1/4"	1 1/2"	2"	2 1/2"	3"	4"	5"	6"	8"	10"
PN 16 bar	∅ D (in)	3.74	4.13	4.53	5.51	5.91	6.50	7.28	7.87	8.66	9.84	11.22	13.39	15.94
	∅ K (in)	2.56	2.95	3.35	3.94	4.33	4.92	5.71	6.30	7.09	8.27	9.45	11.61	13.98
	n x ∅ d1 (in)	4x0.55	4x0.55	4x0.55	4x0.71	4x0.71	4x0.71	4x0.71	8x0.71	8x0.71	8x0.71	8x0.87	12x0.87	12x1.05
PN 25 bar	∅ D (in)	3.74	4.13	4.53	5.51	5.91	6.50	7.28	7.87	9.25	10.63	11.81	14.17	16.73
	∅ K (in)	2.56	2.95	3.35	3.94	4.33	4.92	5.71	6.30	7.48	8.66	9.84	12.20	14.57
	n x ∅ d1 (in)	4x0.55	4x0.55	4x0.55	4x0.71	4x0.71	4x0.71	8x0.71	8x0.71	8x0.87	8x1.02	8x1.02	12x1.02	12x1.18
PN 40 bar	∅ D (in)	3.74	4.13	4.53	5.51	5.91	6.50	7.28	7.87	9.25	10.63	11.81	14.76	17.72
	∅ K (in)	2.56	2.95	3.35	3.94	4.33	4.92	5.71	6.30	7.48	8.66	9.84	12.60	15.16
	n x ∅ d1 (in)	4x0.55	4x0.55	4x0.55	4x0.71	4x0.71	4x0.71	8x0.71	8x0.71	8x0.87	8x1.02	8x1.02	12x1.18	12x1.3

**Stem sealings**

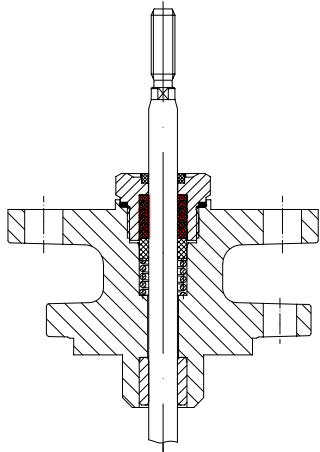

Spring loaded PTFE-V-ring unit

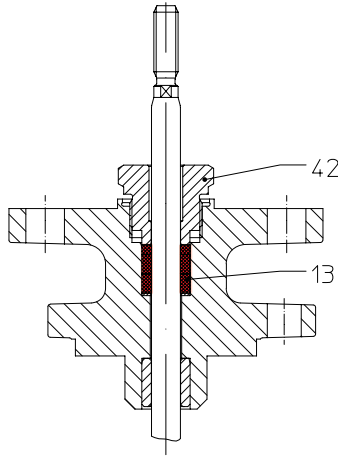

PTFE- / pure graphite-packing

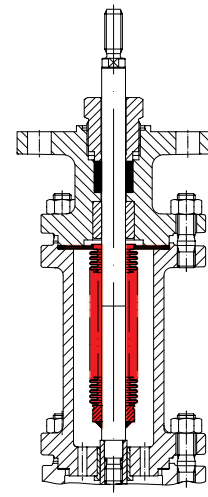

Bellows seal with safety stuffing box

**Operating mode**

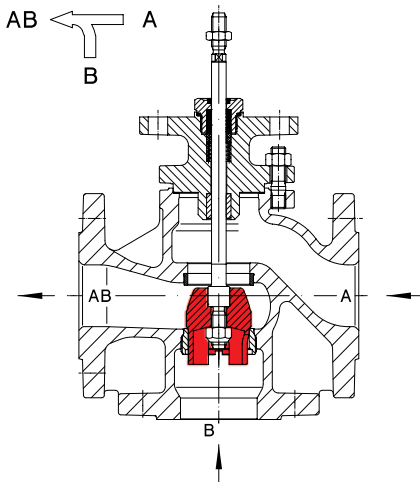

Design with mixing plug Size 1/2" - 6"

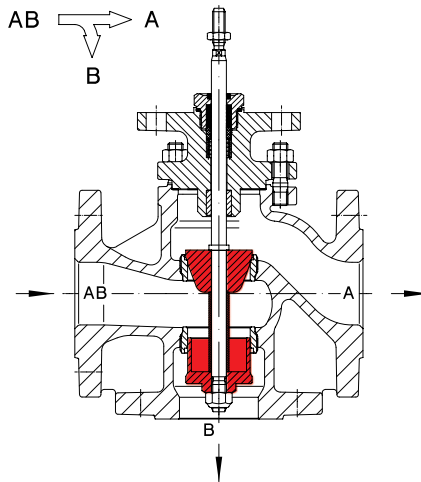

Design with diverting plug Size 1 1/2" - 6"  
 (Attention: reduced Cv-values)

ARI-Control valves are suitable for use with pneumatic or electric actuators.

According to the application two different variations are possible (see drawings on the left)

Design with mixing plug as standard.  
 Select when the valve is used for mixing service (2 inlets, 1 outlet).

Size 1/2" - 1 1/4" with mixing plug can also be used for diverting service (1 inlet, 2 outlets).  
 In exceptions the design with mixing plug can also be used in diverting service for Size  $\geq 1\ 1/2"$ . Only small closing pressures are possible.

Design with diverting plug will be used exclusively for diverting service.



**Technology for the Future.**  
 GERMAN QUALITY VALVES

ARI-Armaturen, USA Inc., 9363 Winkler Drive, Suite A, Houston, Texas 77017, USA, ,  
 Phone 713.947.3622 Fax 713.947.3635, Internet: <http://www.ari-armaturen.com> E-mail: [scris@usa.ari-armaturen.com](mailto:scris@usa.ari-armaturen.com)